



ARISTON

SPARE PARTS EXPLODED VIEW GAS-WALL BOILER ATM. BURNER

Model

HS X - CARES X

R8203464-07 - 24/09/2018

HS X - CARES X

Gas-wall boiler atm. burner

1	3300897	HS X 15 CF NG	09-2016	-
2	3300896	HS X 24 CF NG	09-2016	-
3	3300895	HS X 15 FF NG	09-2016	-
3	3300946	HS X 15 FF (RU)	12-2016	-
3	3301334	HS X 15 FF (RU)	07-2018	-
4	3300894	HS X 18 FF NG	09-2016	-
5	3300893	HS X 24 FF NG	09-2016	-
5	3301337	HS X 24 FF NG	02-2018	-
6	3300889	CARES X 15 CF NG	09-2016	-
7	3300888	CARES X 24 CF NG	09-2016	-
8	3300887	CARES X 15 FF NG	09-2016	-
9	3300886	CARES X 18 FF NG	09-2016	-
10	3300885	CARES X 24 FF NG	09-2016	-
10	3301332	CARES X 24 FF NG	01-2018	-
11	3300891	CARES SYSTEM X 24 CF NG	12-2016	07-2018
12	3300890	CARES X SYSTEM 24 FF NG	12-2016	07-2018

Col	Reference	Model type	Begin	End
-----	-----------	------------	-------	-----

100
200
300
400

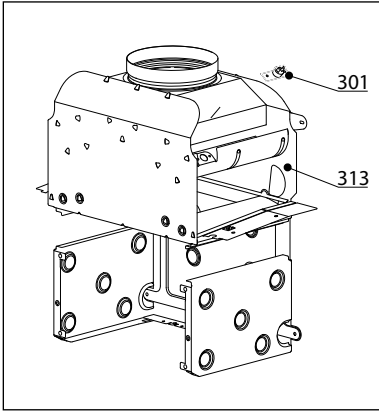

HS X - CARES X

Gas-wall boiler atm. burner

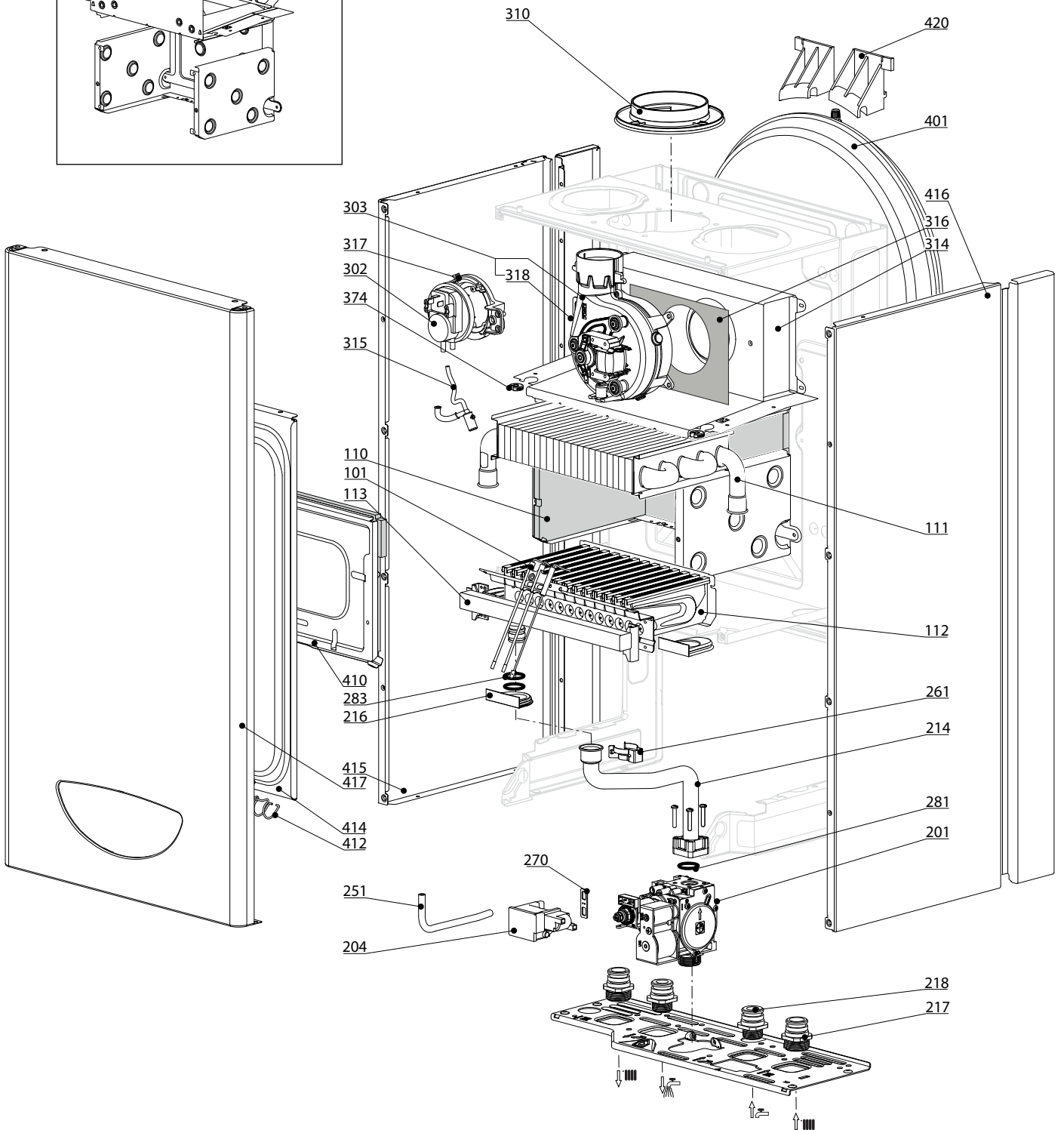

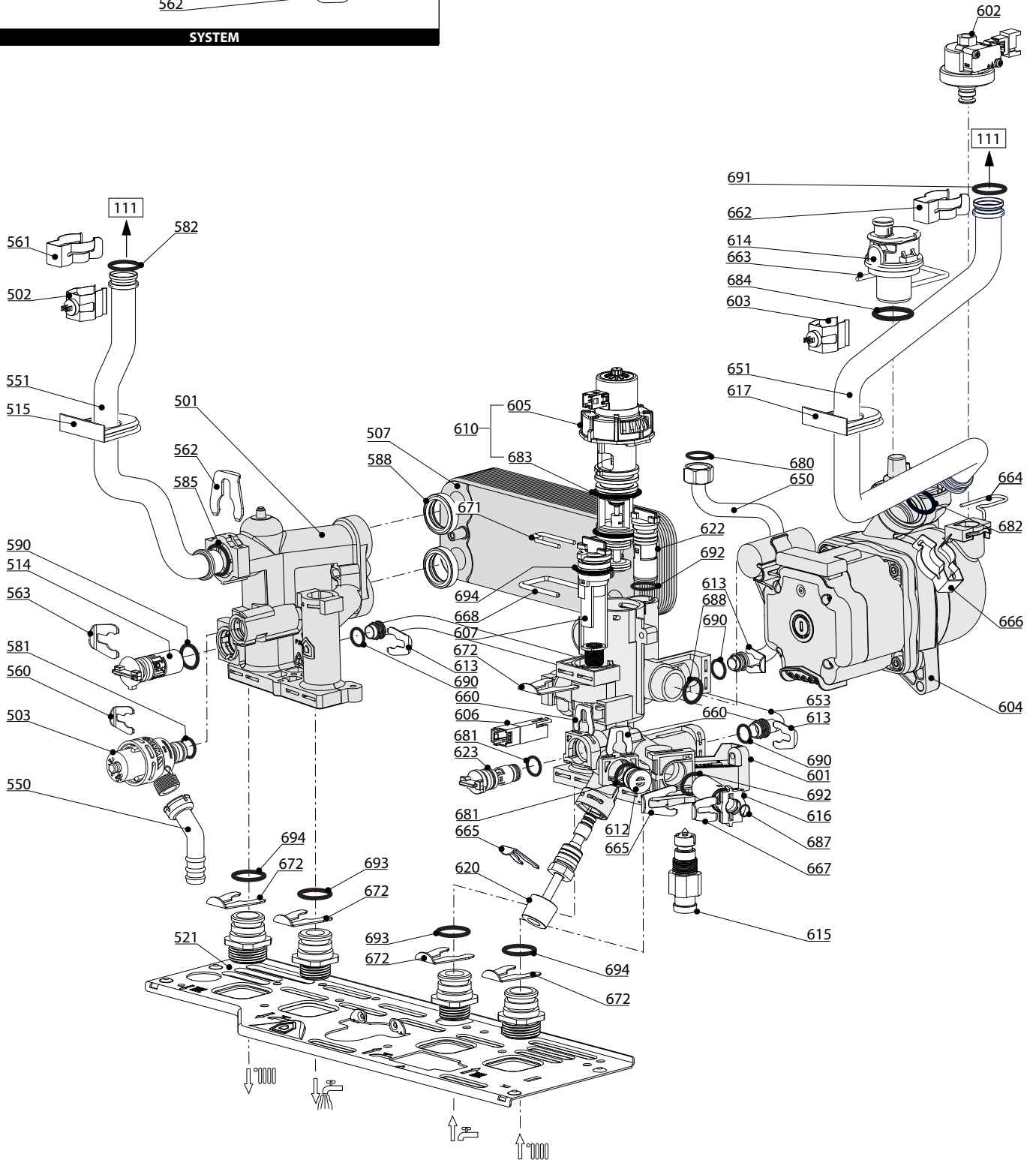
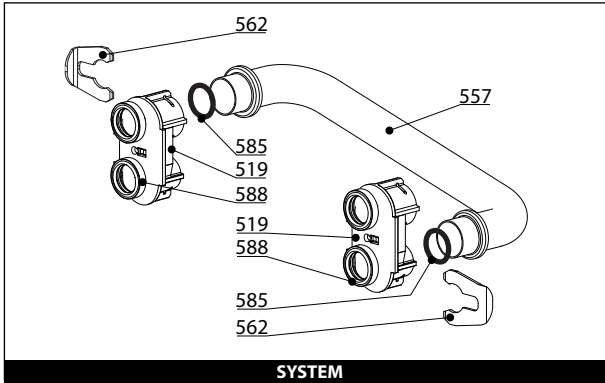

800

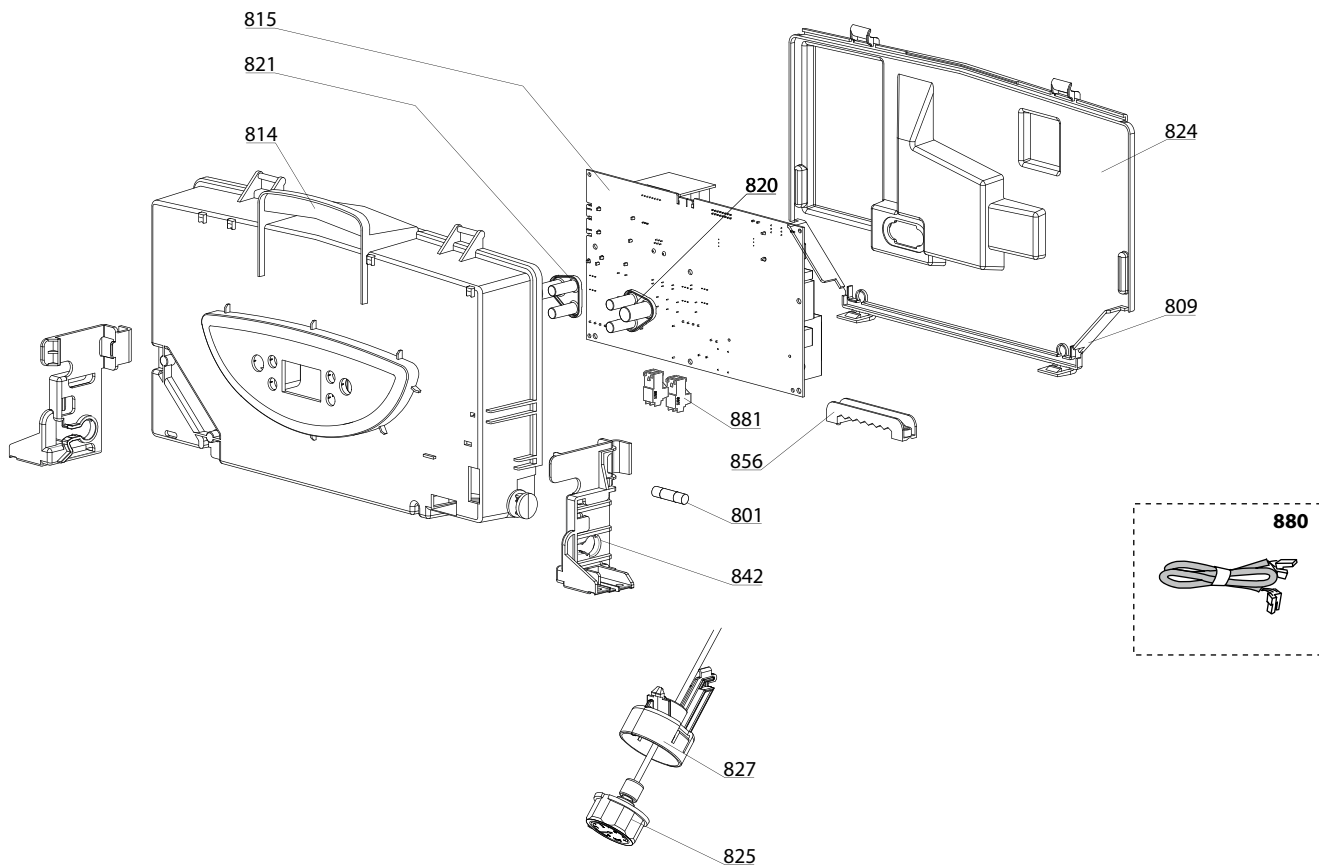

900

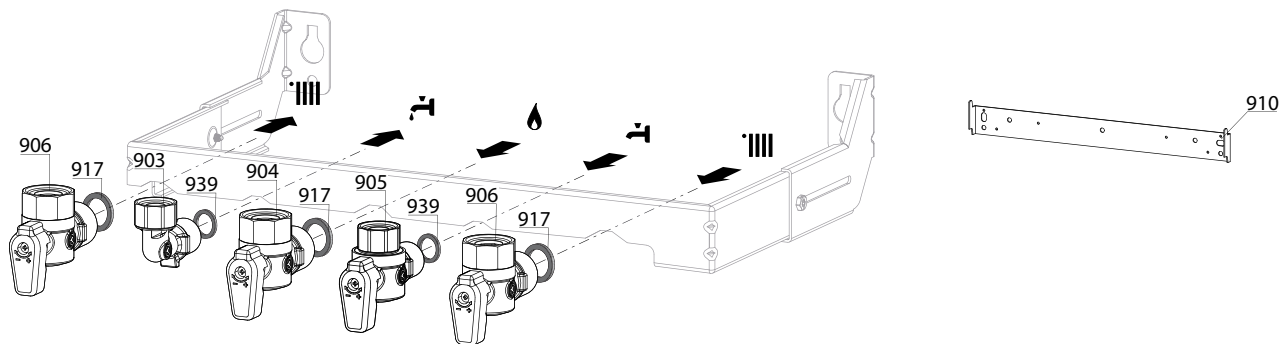

LIST OF THE ABBREVIATIONS

HW	: Hot water.
CW	: Cold water.
C	: Ceramic resistance (normal heating).
Ca	: Ceramic resistance (accelerated heating)
TP	: Immersion heater.
1F	: With fittings.
2F	: Without fittings.
3F	: With fittings and another outlet connection.
AMI	: With mixing valve.
SMI	: Without mixing valve.
PUISS	: Power of th appliance.
PN	: Appliance with normal pression.
LP	: Appliance with low pression.
PV	: Appliance with variable power.
PF	: Appliance with fixed power.

IDENTIFICATION PLATE

SERIAL NUMBER

10 Characters :	04 05 125 011	
		Sequential number
		Manufacturing day
		Year of manufacture
11 Characters :	1 95 065004 - 31	
Month of manufacture :		Technical number of the appliance
from 1 to 9 → Jan. to Sep.,		Sequential number
O → Oct., N → Nov.,		Year of manufacture
D → Dec.		
19 Characters :	08 05 0013199 900640031	
Year of manufacture		Product reference
Month of manufacture		Sequential number
20 Characters :	3675007 XX 2 07 070 00315	
Product reference		Sequential number
Millenium of manufacture		Manufacturing day
		Year of manufacture
21 Characters :	3675007 XX 07 070 0000315	
Product reference		Sequential number
Year of manufacture		Manufacturing day